

Operating Instructions

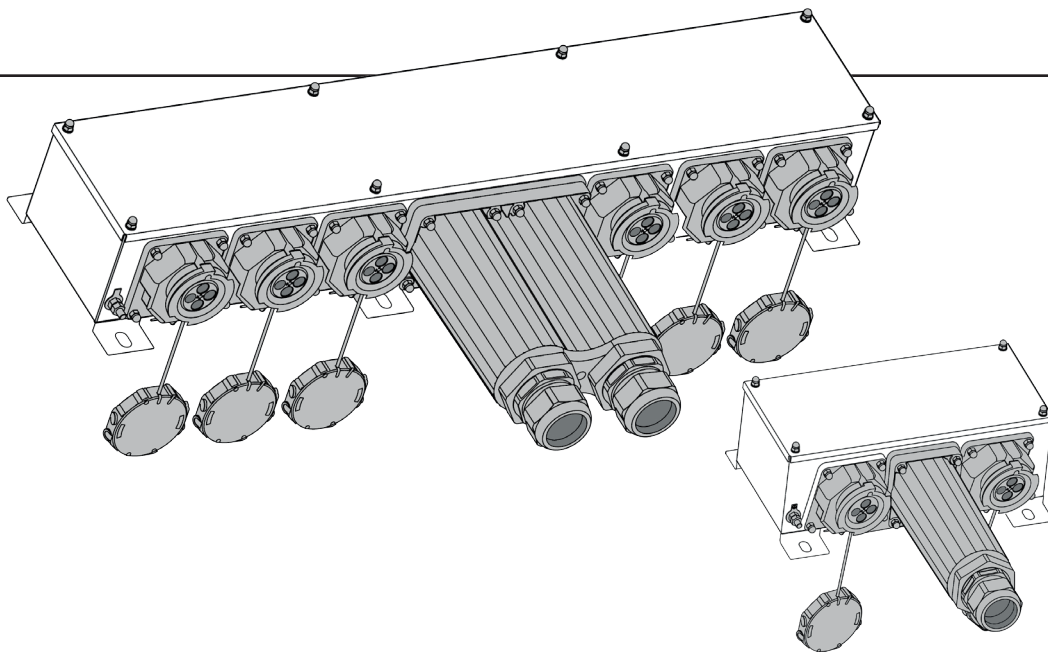

Reefer Container Sockets

Varitain® PushIn Advance

Content Directory

1. Introductory remarks	3
2. Safety instructions	3
2.1. General safety instructions	3
2.2. Electrical voltage	3
2.3. Described models	4
2.4. Change history	4
2.5. Original instructions	4
3. Description and intended use	5
3.1. Functional elements	5
3.2. Intended use	5
4. Operation	6
4.1. Powering the reefer containers	6
4.2. Switch off the reefer container	7
5. Malfunctions during operation	7
6. Maintenance	8
6.1. Cleaning	8
6.2. Regular review	8
7. Disposal and decommissioning	8
8. Mounting and assembly	8
8.1. Preparation	9
8.2. Mounting	10
8.3. Electrical connection	10
9. Commissioning	12
10. Repair	12
10.1. Replacement of the module	12
10.2. Replacement of the housing gasket	15
10.3. Circuit Diagram	17
11. Specifications	18
11.1. Technical data	18
11.2. Dimensional drawings	19
11.3. Product identification	20
11.4. Scope of delivery	20
12. Accessories/spare parts	20
12.1. Spare parts	20
12.2. Accessories	20
13. Declaration of Conformity/Certificate	21

The English version is the original instruction manual.

1. Introductory remarks

These operating instructions are intended for the operator, his personnel and the installer. The instructions help correctly install Varitain PushIn Advance and use it safely in accordance with its intended purpose.







These instructions contain important information on the installation and operation of the Varitain PushIn Advance. By following the given steps, hazards are avoided, repair costs and downtimes reduced and reliability and service life increased.

Read the operating instructions carefully and attentively! WISKA Hoppmann GmbH is not liable for any damages or malfunctions resulting from non-observance of these operating instructions.

2. Safety instructions

The operator bears the responsibility to use the product as described in the intended use.

A warning is issued to indicate dangerous situations to be avoided, followed by an explanation of the situation. The symbols and safety instructions used are as follows:

Icon	Signal word	Meaning
	DANGER	Probable result: Immediate death or serious injury
	WARNING	Possible result: death or serious injury
	CAUTION	Possible result: Slight to moderate injury to persons
	ATTENTION	Possible consequences: Material damage and malfunctions
	Electrician	Installation and repairs may only be carried out by a qualified electrician / electrical skilled person
	Electrical voltage	Injury due to open live parts and components
	Unlocking	Switch off the power before starting work and secure it against being switched on again

2.1. General safety instructions



Installation, commissioning and maintenance should only be carried out by a qualified electrician.

Use Varitain PushIn Advance based on its IP protection class; otherwise, it may get damaged.

Avoid dropping or jolting the Varitain PushIn Advance as it could get damaged.

The tightening torques specified by the manufacturer must be observed.

Allow the LED module to cool for at least five minutes before replacing it.



WARNING: The Varitain PushIn Advance should only be opened or repaired by an authorized electrician.



CAUTION: Disconnect Varitain PushIn Advance from the power source immediately if smoke, sparks, or fumes are emitted, or an unusual odor is detected.

2.2. Electrical voltage

Read this manual carefully. If applicable, also consider the operating instructions of other manufacturers.

Install Varitain PushIn Advance as described in this manual.

ATTENTION: Electrical connections and connection cables must comply with all relevant regulations.

ATTENTION: Observe the safety regulations for electricians: Before starting any installation or maintenance work, disconnect the power supply, secure it from being switched on again, check that no voltage is present,

earth, and cover adjacent live parts and if necessary short-circuit.

! **WARNING:** Danger of an electric shock.
Varitain PushIn Advances must not be installed outdoors in rainy weather

! **CAUTION:** Risk of fire or an electric shock
Observe the load limits of extension cables and sockets to avoid the.

! **WARNING:** Danger to life
Never repair damaged power cables!
Disconnect the reefer container socket Advance from the mains and have it repaired.

All cables and accessories must be professionally installed to function reliably.

Consider the national and local installation requirements and classification rules. In some countries, lighting may only be installed by registered installers.

Clamping screws in electrical connections must be tightened as specified by the manufacturer.

Observe the symbols for connecting the cables in accordance with national directives:

N = Neutral L = Phase  = Earth LS = Live, switched.

2.3. Described models

The Varitain PushIn Advance comes in a wide variety of models and options. The described models are the standard models:

Varitain PushIn Advance xx / M 50 / 10 kA, Varitain PushIn Advance xx / M 50 / 25 kA
xx denotes the number of gangs on the right and left side up to a total of 4 gangs.

Varitain PushIn Advance xx / M 63 / 10 kA, Varitain PushIn Advance xx / M 63 / 25 kA
xx denotes the number of gangs on the right and left side with a total of 5 to 10 gangs.

Different numbers of gangs on the left and on the right side are possible.

2.4. Change history

Version	Revision date	Changes
1.0	05/2023	first edition

2.5. Original instructions

The English version of this document is the original manual.

3. Description and intended use

The Varitain PushIn Advance reefer container sockets enable the voltage-free connection of reefer containers to the 440V on-board network of a container ship or on land in terminal parking spaces.

The reefer container socket is permanently installed and can be used outdoors or in the cargo hold. The device fulfills a degree of protection IP66 / IP67.

The number of sockets varies between 1 and 10 socket outlets arranged on one or both sides, depending on the model. The power connection is done inside the sleeve to avoid any water ingress due to opening the case.

The reefer container socket consists of the housing Advance, the CEE socket insert and a connection for the power supply from the vehicle electrical system.

The CEE socket has a power switch for 440V ±10% (3-phase) and can switch a maximum of 32A. The built-in protective device protects the circuit against short circuits and overloads.

Due to the design of the CEE socket insert, an incorrect plug direction of the plug is impossible.

The LED indicator element indicates whether the container is supplied with power.

The intact factory seal shows that the device is properly closed and the lid has not been opened. This certifies that no changes have been made to the product.

3.1. Functional Elements

[Varitain PushIn Advance 44]

[CEE socket gang]

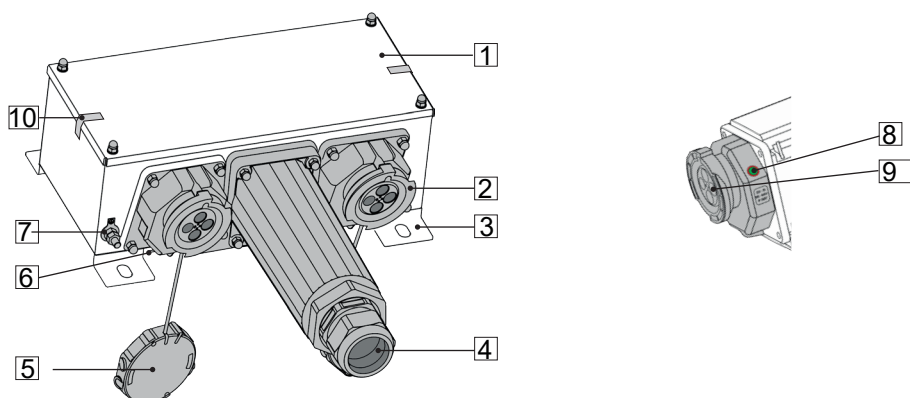

Pos.	Designation	Pos.	Designation
1	Case	6	Venting element (option)
2	CEE socket gang	7	Earth bolt
3	Mounting bracket	8	LED indicator (green)
4	Sleeve / cable gland / Power input	9	Contacts
5	Bayonet cap	10	Factory seal

3.2. Intended use

Varitain PushIn Advance is designed to power reefer containers on ships. Its usage is forbidden in the following scenarios:

- To use the Varitain PushIn Advance either as a step or as a stand or to sit on the Advance.
- To use a Varitain PushIn Advance with the sockets facing upwards.
- To open the Varitain PushIn Advance during operation.
- To use the Varitain PushIn Advance as a storage surface

4. Operation

If the product is not to be used for an extended period of time, no preparation is required.
 A visual inspection before recommissioning is recommended.
 Connection only by an electrically qualified person.



4.1. Powering the reefer containers

According to international regulations, the plugs of the reefer containers' cables can only be plugged in and unplugged when the circuit-breaker is open.

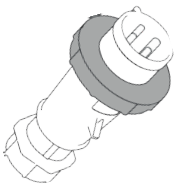
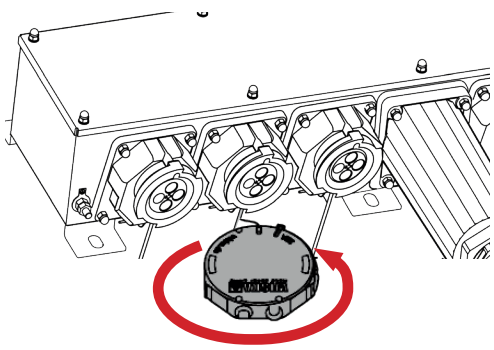
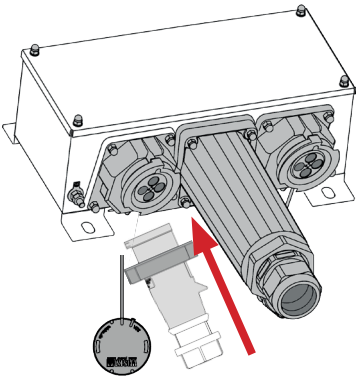
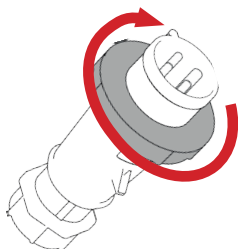
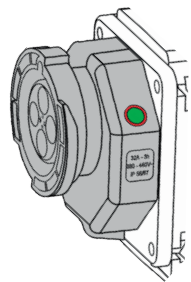

Preparations

1	<p>Check before connecting:</p> <ul style="list-style-type: none"> ✓ The plug housing is undamaged. ✓ The bayonet ring is available with unspoiled seal. ✓ The plug is clean and dry. ✓ The auxiliary projection of the plug is present. ✓ The plug complies with the valid standards IEC 60309-1, IEC 60309-2.
----------	--

Connecting the reefer containers

2	<p>Check if the connection of the reefer container works.</p> 	i	<p>Notice Use only approved plugs. Check plug for compatibility before use. Connectors that comply with the standard are permitted. No power supply to the CEE socket with other plugs.</p>
3	<p>Lay the cable to the CEE socket gang.</p>	!	<p>Caution Tripping hazard. → Lay cables in accordance with IMO regulations in the intended cable routing zones.</p>
4	<p>Turn the bayonet cap of the socket counterclockwise and remove it.</p> 	5	<p>Push the CEE plug firmly into the socket.</p> 
6	<p>Slide the bayonet ring over the bush. Tighten clockwise.</p> 	7	<p>The LED lights up green.</p> 
8			

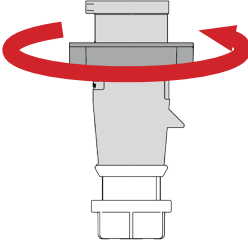
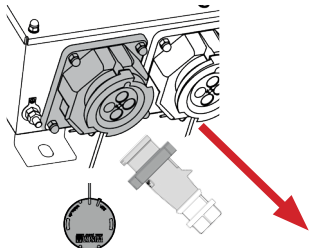
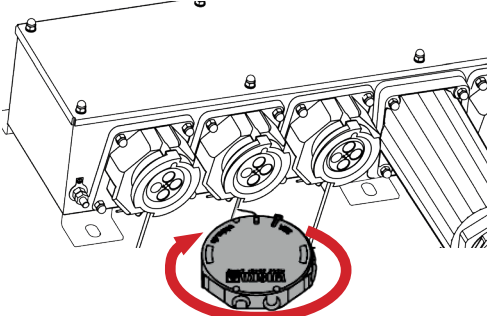
4.2. Switch off the reefer container

<p>Turn the bayonet ring of the CEE plug. Turn counterclockwise. The power socket is switched off.</p> 	<p>2 Pull the plug out of the socket. The LED is off.</p> 
<p>3 Attach the bayonet cap. Turn clockwise to fix it.</p> 	<p>4</p> 

5. Malfunctions during operation

Repairs and maintenance must only be carried out by skilled personnel with proven qualifications. In case of malfunctions, first consider the measures listed below:

Problem	Cause	Remedy
Indicator does not light up	Power supply is interrupted LED defective Socket module is defective Fuse failed/is short Incorrectly connected Connection cable is defective	Check/ re-establish the power supply. Ask the electrician to replace the LED. Ask the electrician to replace the the socket module. Eliminate the error and then switch on the fuse. Ask the electrician to check the connection. Ask the electrician to replace the connection cable or LED module.
All indicators distinguished	Power loss	Remove the plugs and re-insert them.
Outlet not switched on	Connection: Plug not tight. No power. Power outage.	Pull out the plug and insert it firmly. Connect the power supply via the main switch. Check Power supply. Check fuse. Make sure that no live cables are defective. Pull out the plug and insert it firmly again.
Moisture in the housing	Wrong mounting alignment. Condensation	Reinstall (sleeve pointing downwards) or protect entries. Check venting plug (option): Replace or clean.
Lead cable damaged Conductors visible	Buckling, cut or crushing	Inform ship's electrician.
Plug does not snap into place	Contamination No contact	Cleaning Disconnect power before use. Try with more force
Seal damaged	Housing open	Check function

6. Maintenance

6.1. Cleaning



WARNING

Risk of electric shock!

Disconnect the Varitain PushIn Advance from voltage sources before cleaning any contacts.

ATTENTION

Do not use solvents, petrol, alcohol while cleaning. Further, do not use sharp-edged tools, screwdrivers, metal brushes, or the like. They can damage the surfaces of the Varitain PushIn Advance.

Clean the outer surfaces with a soft, dry cloth. In case of heavy soiling, slightly moisten the cloth with clear water

6.2. Regular review

The Varitain PushIn Advance is maintenance-free if it is carefully treated. In case of problems or malfunctions, please refer to the chapters “Malfunctions” and “Maintenance.”

Perform visual and functional tests at regular intervals - at least once a month.

The examination should include:

- A visual inspection for damage and heavy soiling of the case.
- A visual inspection for damage or rust on the retaining bracket and fixing screws.
- A visual inspection for damage to the cables.
- A visual inspection of completeness.
- A visual inspection of the bayonet ring and its undamaged seal.
- A visual inspection of the auxiliary overhang of the plug.
- A visual inspection whether the plug is according to valid standard.
- A visual inspection of the VentPLUG.
- A function test of the retaining bracket.
- A test for noises (cAdvanceling, humming) and heated supply lines.

7. Disposal and decommissioning

Comply with the local and national laws, guidelines and regulations regarding the disposal of materials and products.

Waste Electrical and Electronic Equipment (Applicable in the European Union and other European countries with separate collection systems.)

The electrical appliances by WISKA Hoppmann GmbH are professional electrical appliances, which are also called business-to-business (B2B) appliances. We take back old electrical appliances in accordance with the national WEEE law (i.e., in Germany § 19 ElektroG), and dispose of them properly. Please contact us before shipping your old WISKA electrical appliances at contact@wiska.de. Components, such as cable glands, do not fall under this law.

Do not mix or dispose of old electrical equipment from WISKA Hoppmann GmbH with other commercial waste.

8. Mounting and assembly

Installation, commissioning, maintenance, and repair should exclusively be carried out by skilled personnel with proven qualifications.



DANGER

Danger to life from electric currents

Working on open circuits can result in short circuits and body shorts.



- An electrician should be present when working on electrical components.
- Make sure that the system is disconnected from the electrical connection.
- Secure the power supply against being switched on again.
- Cover open external plant components.
- If necessary, short-circuit the system components.
- Test whether the system is voltage-free.

8.1. Preparation



Required tools: Foot rule, drill machine

ATTENTION

The housing may warp and leak. Install on a level surface solely.

CAUTION

Fire or malfunction through kinked or broken cable. Observe the bending radius of the power supply cable to positioning the housing.

1 Mark the mounting position.

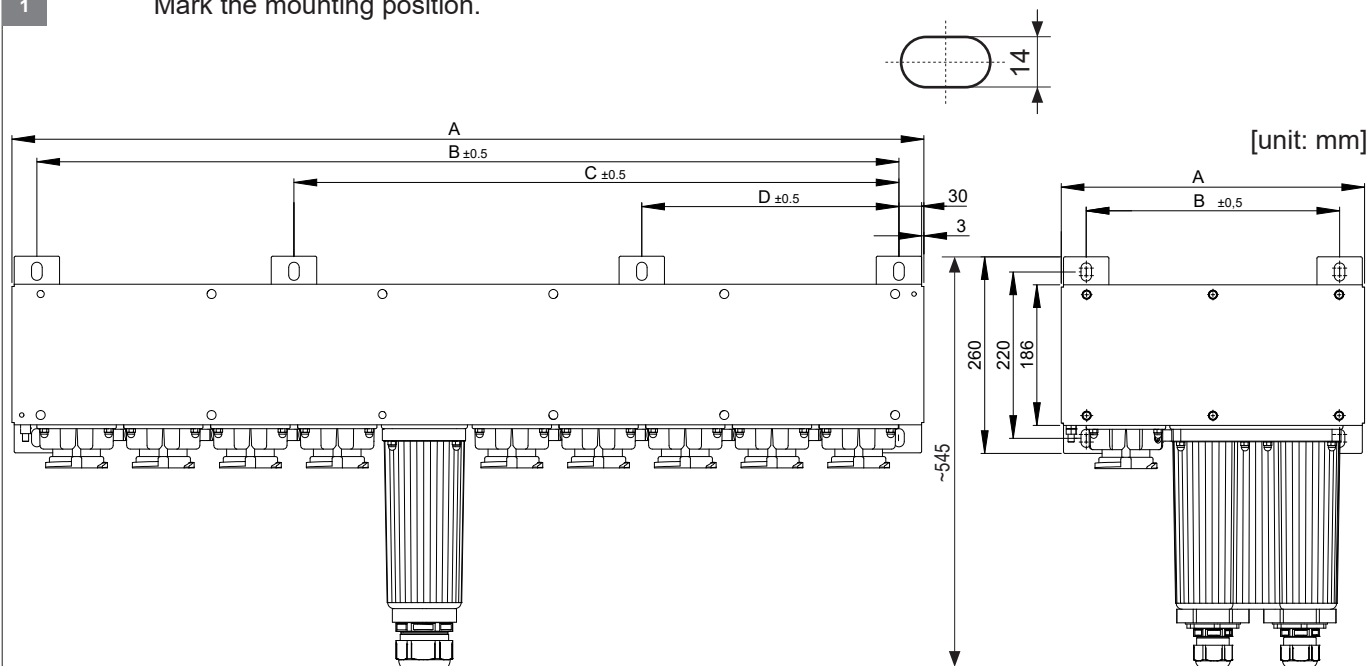

Varitain PI Advance		Mounting Holes	Length [mm]			
Standard version	Looping version		A	B	C	D
1-gang	-	4	286	220	-	-
2-gang	1-gang-looping	4	401	335	-	-
3-gang	2-gang looping	4	516	450	-	-
4-gang	3-gang looping	4	631	565	-	-
5-gang	4-gang looping	6	746	680	460	
6-gang	5-gang looping	6	861	795	455	
7-gang	6-gang looping	6	976	910	575	
8-gang	7-gang looping	6	1091	1025	570	
9-gang	8-gang looping	8	1206	1140	800	340
10-gang	9-gang looping	8	1321	1255	915	455
-	10-gang looping	8	1436	1370	915	455

1 Some models are supplied with the sleeve removed. For all models: A free space of at least 650 mm is required to attach the sleeve. Provide enough spare space for proper installation of the power supply cable.

2 Either drill the holes or use welding bolts with nuts (either a drill machine or a stud welding machine is required).

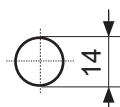

3

8.2. Mounting



Required tools: Screwdriver, open-end wrench, ratchet lever.



Required materials: M12 stainless steel screws and washers x 8 (Varitain PushIn Advance 5x/ x5)/ x 6 (all other)



CAUTION
Varitain PushIn Advance is heavy!
 Injuries and damage from falling are possible.



Use lifting gear if applicable.
 Secure the Varitain PushIn Advance using another person's help

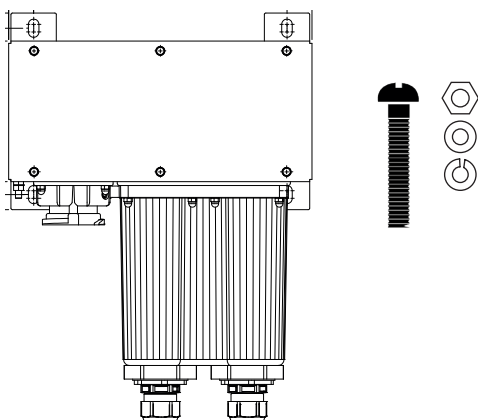

<p>1 Mount the Varitain PushIn Advance to the wall.</p> 	<p>1 Use for each screw and 8 washers for Varitain PI Advance 9 and 10 Use 6 screws and 6 washers for Varitain PI Advance 4 to 8. Tightening torques 25 Nm</p> <p>2 ✓</p>
---	--

8.3. Electrical connection



DANGER

Danger to life from electric currents

Working on open circuits can result in short circuits and body shorts.



- An electrician should be present when working on electrical components.
- Make sure that the system is disconnected from the electrical connection.
- Secure the power supply against being switched on again.
- Cover open external plant components.
- If necessary, short-circuit the system components.
- Test whether the system is voltage-free.

ATTENTION Make sure that a fuse is installed in the electrical supply line.

Characteristic data	
Nominal voltage	440V AC, 50/60 Hz
Breaking capacity	10 kA or 25 kA (depending on model).
Current	32 A
Wire cross-section	Max. 3x120 mm ² (max.3x AWG 4/0)
Cable diameter	34-48 mm (1.34" – 1.89", cable gland M63) or less with optional RDE insert. 21-35 mm (0.83" – 1.38", cable gland M50) or less with optional RDE insert.

<p>Required tools</p>	<p>Cap nuts of cover: Hexagon wrench AF10 and AF17. Cable gland key: ESKV 63: AF68 mm or EMSKV 50: AF55 mm. Cable shielding: Side cutter. Conductors: Insulation stripping pliers, screwdriver. Crimping tool for ferrules: crimping pliers or cable lugs.</p>
<p>Required materials</p>	<p>Power supply cable: Use L1, L2, L3, and Protective Earth (PE), and the cable shield. 3 wire end ferrules (only Varitain PushIn Advance 2x/ x2) or lugs (all other).</p>
<p>Prepare the power supply cable.</p>	<p>Strip the cable insulation and bend the cable shield. Strip each conductor's insulation approx. 10 mm. Varitain PushIn Advance 3x/ x3/ 4x/ x4/ 5x/ x5 only: Fit and press the wire end ferrules or M10 cable lugs.</p> 

1 Loosen the cap nut of the cable gland.

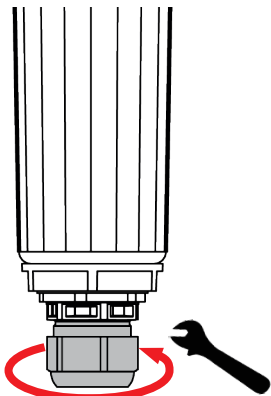

2 Only if the model has a sleeve attached:
 Screw up the sleeve : 4 screws
 Open it

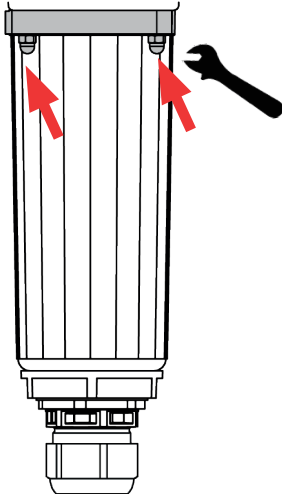

ATTENTION
 When removing the cover, ensure that the seal is undamaged.

3 Insert the cable through the sleeve with the cable gland

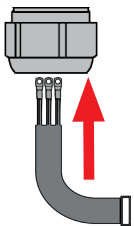

4 Put the Earthing inner ring over the wires and under the screen.

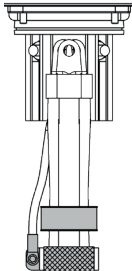

5 Lay on the Earthing outer ring with the PE wire

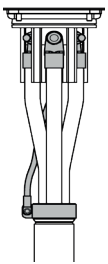

6 Lay on the Phase (L1, L2, L3) conductors

i The tightening torque for the screws should be 15 Nm

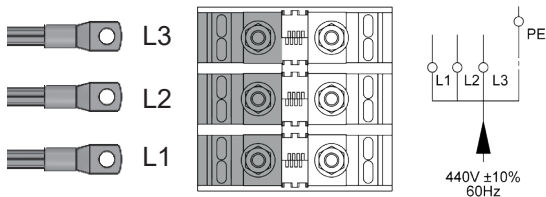

7 Screw down the sleeve with the cable gland

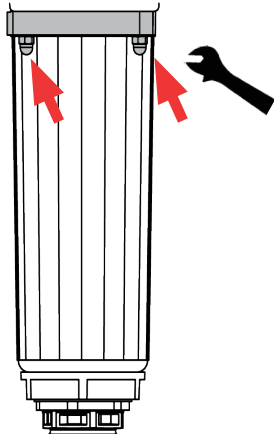

i The tightening torque for the cable gland's cover should be **8Nm!**

ATTENTION

Seal the cable gland with a reducing insert, if necessary.

8 Screw-down the cable gland's cap nut

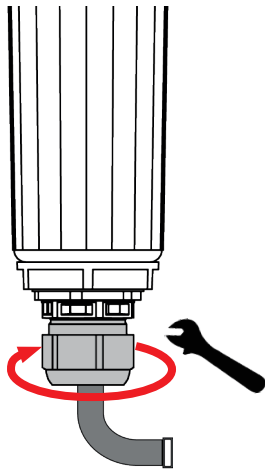

9 Connect the earthing bolt
Connect the earthing cable to the ship's earthing.

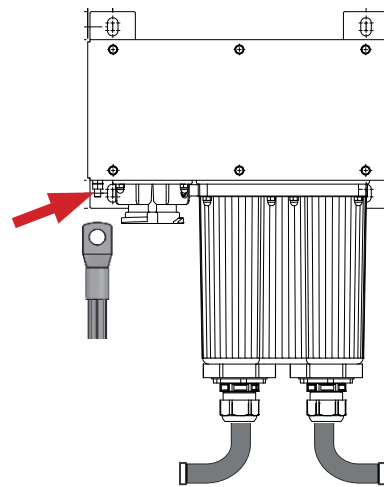

ATTENTION:

Ensure that the cover's seal is intact.
Else water may intrude.

10





9. Commissioning

Required tools	CEE plug
Visual inspection	All connection screws are fixed.
Functional test	Connect the CEE plug LED lights: ok.

10. Repair

DANGER

 Danger to life from electric currents.
Working on open circuits can lead to short circuits and body short-circuits.

 An electrician must be present when working on electrical components.



- Make sure that the system is disconnected from mains.
- Secure the power supply against being switched on again.
- Cover open external plant components.
- If necessary, short-circuit the system components.
- Test whether the system is voltage-free.

10.1. Replacement of the socket module

DANGER of electric shock.

Disconnect the Varitain PushIn Advance from the power supply.
Observe safety measures to prevent reconnection.

ATTENTION Only use socket modules with suitable breaking capacity.

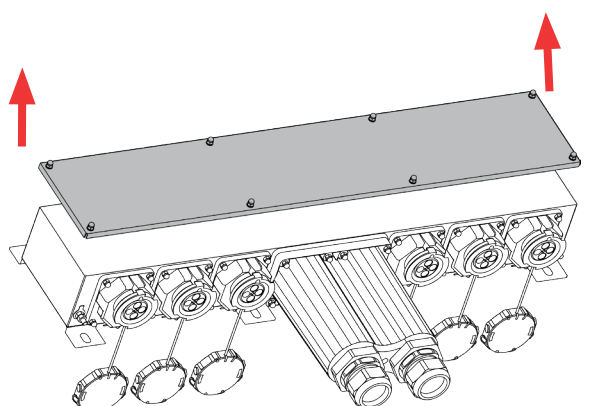
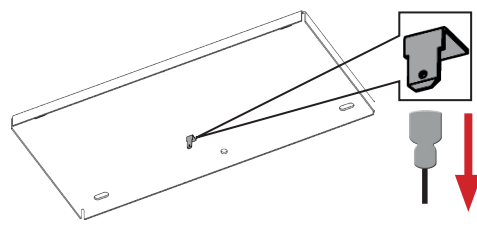
Required tools	Screwdrivers (reuse the screws) 
 CAUTION Switch off the Varitain PushIn Advance and disconnect the connection cable before starting the maintenance process.	
<p>1 Open cover.</p>  <p>ATTENTION Make sure the seal is undamaged when removing the cover.</p>	<p>2 Disconnect the PE connector from the inner cover.</p> 

3 Loosen the cabling from the socket module.
Mark the cables for reconnecting.

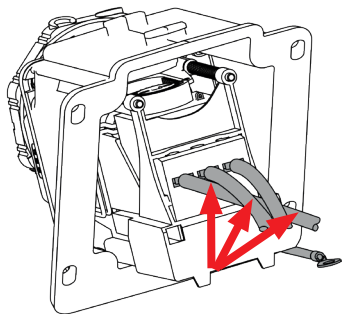

4 Remove the PE connector next to the socket module.

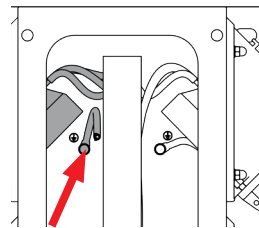

5 Screw up the socket module.

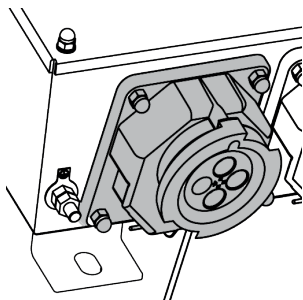

6 Pull the socket module out

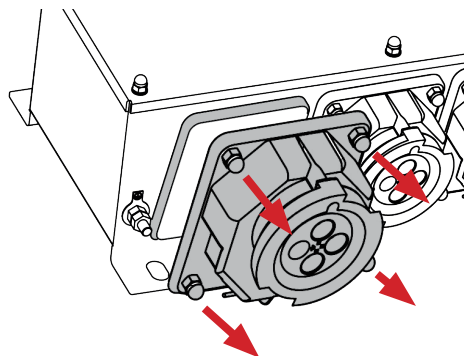

7 Insert the new socket module. Tighten the nuts.

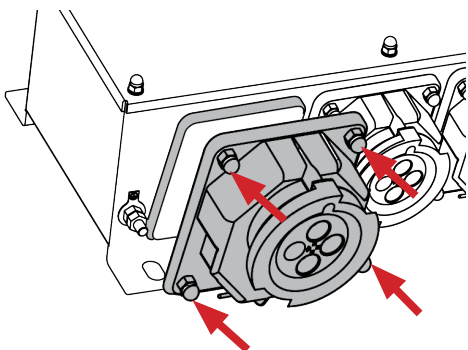

8 Reconnect the PE next to the socket module

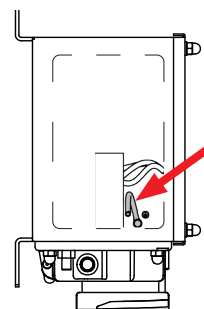

i Tightening torque: **3 to 3.5 Nm**

9 . Reconnect the leads

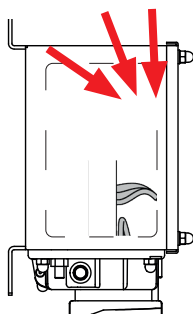

10 . Slide the PE connector into the cover's receptacle.
Close the cover.
Use the washers.

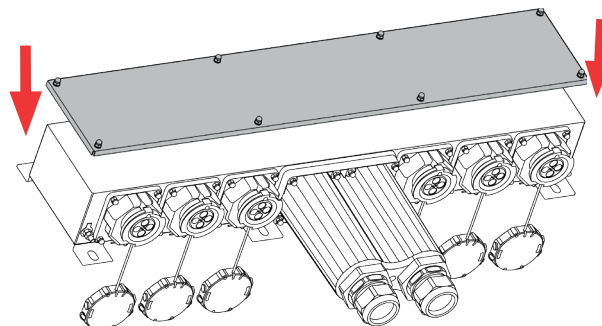



i Cable tightening torque: **1.7 Nm**

i Tightening torque: **4.5 Nm**

10

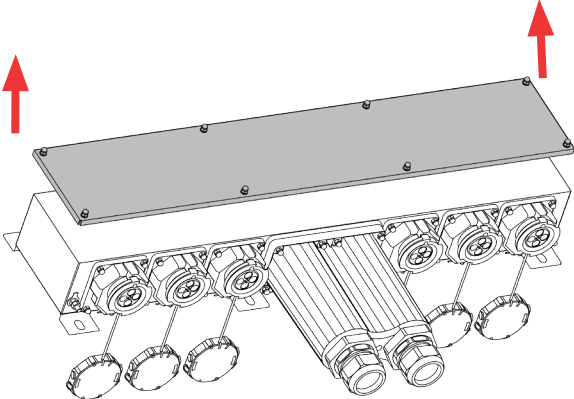
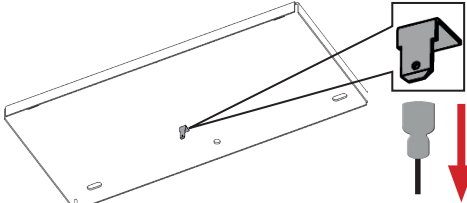
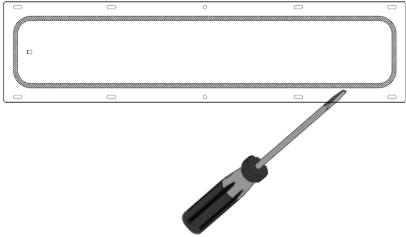
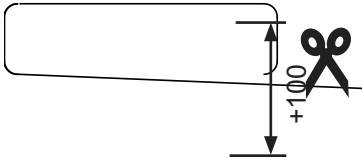

10.2. Replacement of the housing gasket

<p>Required tools</p>	<p>Screwdriver, gloves, cutter or scissors (reuse the screws)</p>
<p>Required materials</p>	<p>Lid gasket (see spare parts list)</p>
<p>i The new gasket is attached to the housing's inner edge.</p>	
<p>CAUTION Switch off the Varitain PushIn Advance and disconnect the connection cable before starting the maintenance process.</p>	
<p>1 Open cover.</p> 	<p>2 Disconnect the PE connector from the inner cover.</p> 
<p>! Cautionously remove the old gasket by means of a screwdriver.</p> 	<p>4 Measure the required length housing's inner edge. Add 100 mm. Cut the new gasket.</p> 
<p>! CAUTION Glue may cause irritation of the skin and respiratory tract</p> <ul style="list-style-type: none"> • Do not inhale. • Wear gloves. 	
<p>5 Apply WeiconContact VA 2500HT glue to the gasket: Apply over the entire length of the inner side.</p> 	<p>6 Press the gasket on to the housing's inner edge.</p>

7 Fix the seal to the curves.

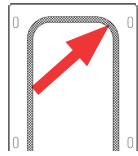

8 Cut off the seal, leaving an overhang of 3-5 mm.

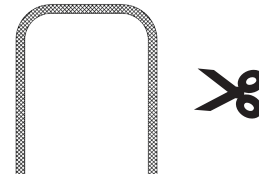

9 Apply the adhesive WeiconContact VA 8312 to the front ends of the seal.

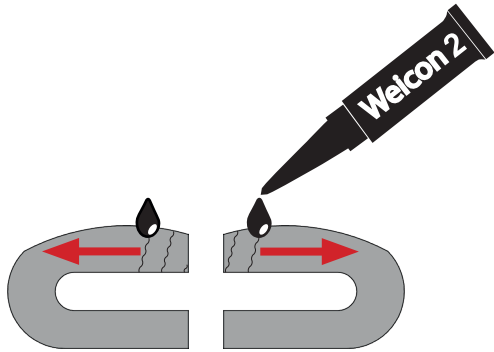

10 Press the ends of the seal together. Press the seal firmly onto the cover.

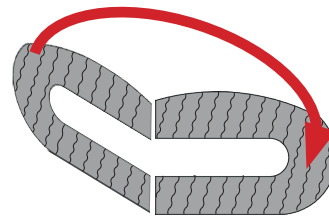

i Only careful joining and sticking of the two seal ends guarantees a functional seal.

11 Slide the PE connector into the cover's receptacle.

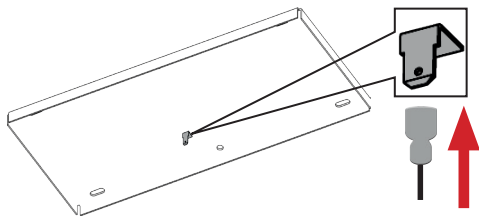

12 Close the cover. Use the washers

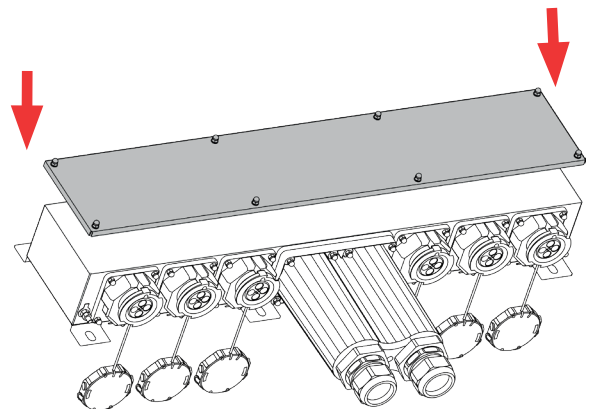

i Tightening torque: **4.5 Nm**

13



10.3. Circuit Diagram

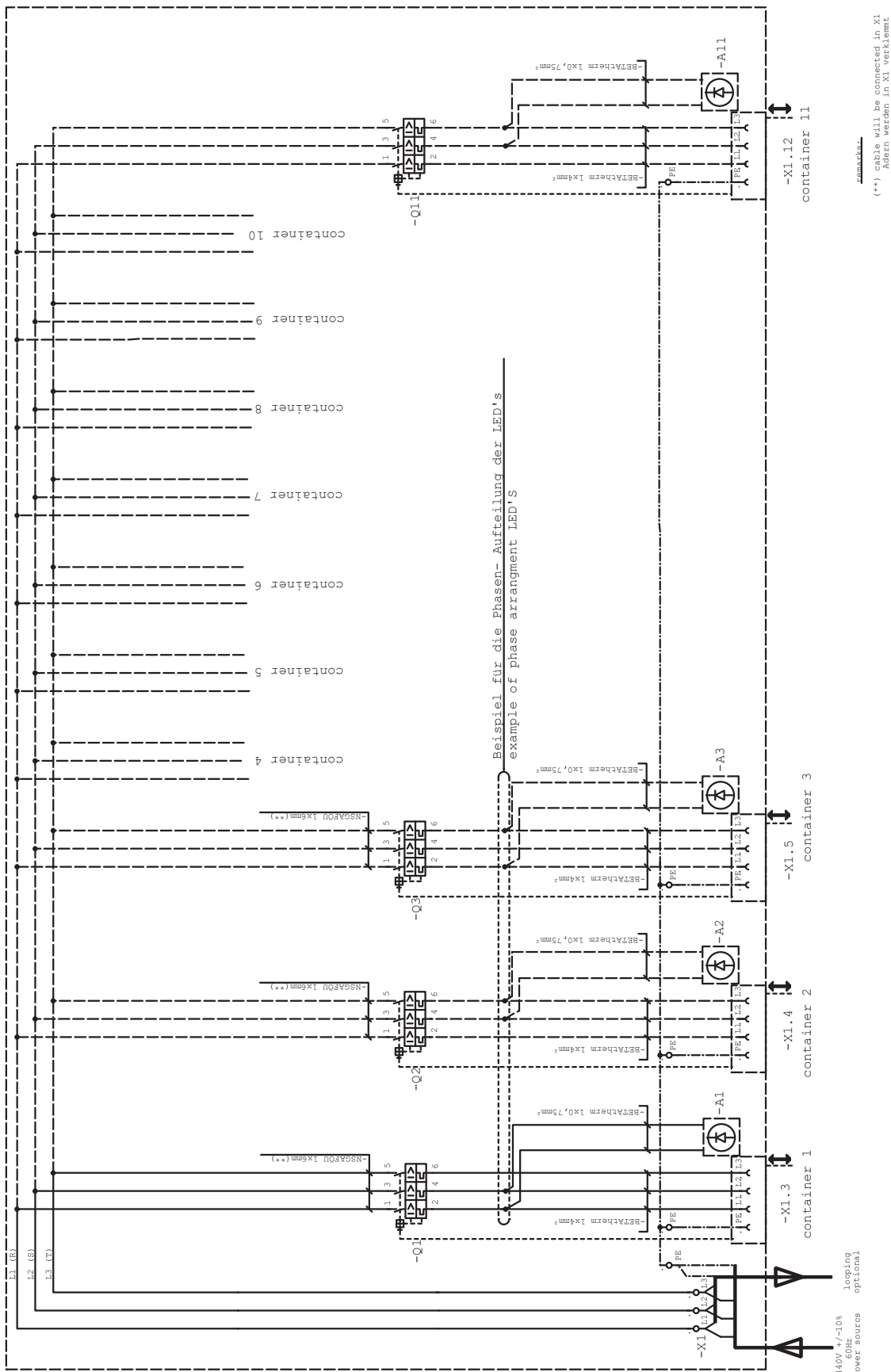

11. Specifications

11.1. Technical data

All data refer to the standard models.

- Varitain PushIn Advance xx/FS/FS/32A/25kA/LED/G with 25kA breaking current
- Varitain PushIn Advance xx/FS/FS/32A/10kA/LED/G with 10kA breaking current

Custom made models may have different dimensions and configurations.

Specification			
Material	Stainless steel 1.4301 (V2A)		
Material protective cap	Polyamide		
Socket insert	3 - poles + PE		
Clock face position	3 h		
Breaking capacity	25 kA or 10 kA		
Voltage max. (V)	440 V AC		
Current	32 A		
Protection class	IP66 / IP67		
Operational areas	Outdoor		
Temp. range min	-25°C to 45°C (-13°F to 113°F)		
Type of cable gland*** Optional inserts	ESKV 40 ** RDE40	ESKV 50 ** RDE50	ESKV 63 ** RDE63
Mounting	Wall, surface mounting		
Colour	RAL 9016		
Approval	DNV		

* Including the mounting bracket

** Standard configuration

*** Depending on configuration and number of gangs

Dimensions /Weights

Varitain PI Advance		Mounting	Length [mm]	Height [mm]	Depth [mm]	Weight [kg]
Standard version	Looping version	Holes		approx	approx.	approx.
1-gang	-	4	286	166	542 - 547	6
2-gang	1-gang-looping	4	401	166	542 - 547	8
3-gang	2-gang looping	4	516	166	542 - 547	10
4-gang	3-gang looping	4	631	166	542 - 547	12
-	4-gang looping	6	746	166	542 - 547	14
5-gang	-	6	746	166	542 - 547	16
6-gang	5-gang looping	6	861	166	542 - 547	18
7-gang	6-gang looping	6	976	166	542 - 547	18
8-gang	7-gang looping	6	1091	166	542 - 547	20
9-gang	8-gang looping	8	1206	166	542 - 547	22
10-gang	9-gang looping	8	1321	166	542 - 547	24
-	10-gang looping	8	1436	166	542 - 547	26

11.2. Dimensional drawings

The numbers of gangs varies between one and 10. Each model is available as single power connection or looping power connection. Measures depend on the individual model.

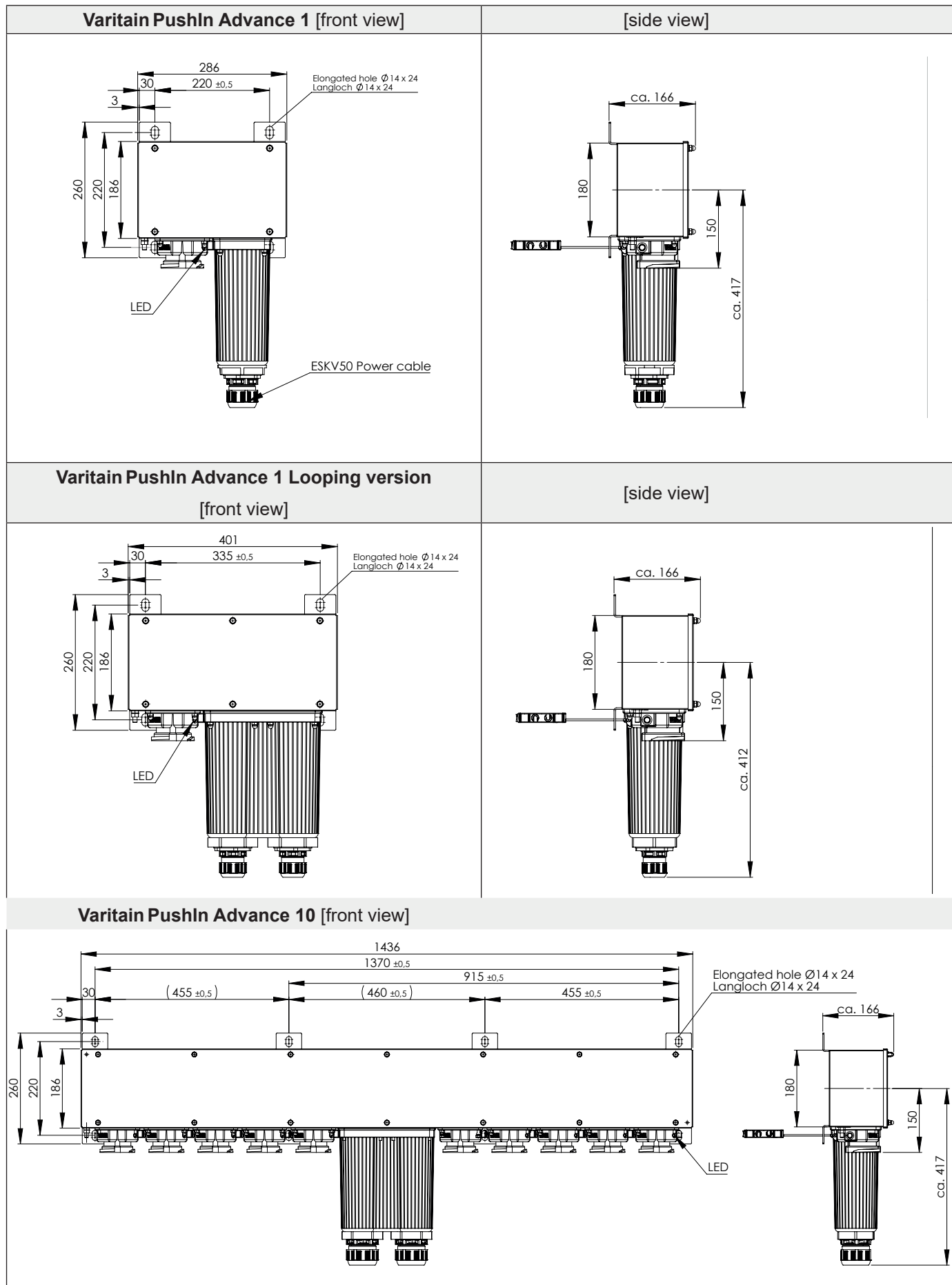

[unit: mm]

11.3. Product identification



The type label has a three-row design and includes the following:

Pos.	Designation
1	Article series
2	Performance data
3	Power supply data
4	Article Type
5	Serial number
6	Identification index
7	Country of origin

11.4. Scope of delivery

The Varitain PushIn Advance is mainly custom made.

It features the housing, the cable gland and the brackets.

It optionally features a pressure compensation plug. Further options are available based on the order.

12. Accessories/spare parts

Use only original WISKA accessories and spare parts. Accessories and spare parts (e.g., cable glands, pressure compensation plugs, seals). They can be obtained from WISKA Service.

12.1. Spare parts

No.	Designation	Article no.
1	Cap nuts	22000402
2	Socket module, complete	
2.1.	10 kA	22000426
2.2	25 kA	22000427
3	Bayonet cap with fastening belt	22000403
4	Lid gasket	22000431
5	VentPLUG (M12)	22000430

12.2. Accessories

VentPLUG: Pressure compensation plug

13. Declaration of Conformity/Certificate

The declaration of conformity for each Varitain PushIn Advance can be found on www.wiska.com.

Certificate



TYPE APPROVAL CERTIFICATE

Certificate No:
TAE00002T8
Revision No:
2

This is to certify:

That the **Socket Outlet**

with type designation(s)
VARITAIN PushIn, PushIn Advance and PushIn Rack

Issued to
WISKA Hoppmann GmbH
Kaltenkirchen, Germany

is found to comply with
DNV rules for classification – Ships, offshore units, and high speed and light craft

Application :

Product(s) approved by this certificate is/are accepted for installation on all vessels classed by DNV.

Rated voltage (V) 500 V
Rated current (A) 32 A
Degree of protection IP 56 /IP 67

Issued at **Høvik** on **2023-05-02**

This Certificate is valid until **2028-05-01**.
DNV local unit: **Hamburg – CMC North/East**

Approval Engineer: **Uwe Supke**

for **DNV**



Digitally Signed By: **Alonso Pontes, Marta**
Location: **DNV Høvik**

Marta Alonso Pontes
Head of Section

This Certificate is subject to terms and conditions overleaf. Any significant change in design or construction may render this Certificate invalid.
The validity date relates to the Type Approval Certificate and not to the approval of equipment/systems installed.

LEGAL DISCLAIMER: Unless otherwise stated in the applicable contract with the holder of this document, or following from mandatory law, the liability of DNV AS, its parent companies and their subsidiaries as well as their officers, directors and employees ("DNV") arising from or in connection with the services rendered for the purpose of the issuance of this document or reliance thereon, whether in contract or in tort (including negligence), shall be limited to direct losses and under any circumstance be limited to 300,000 USD.



Form code: TA 251

Revision: 2022-12

www.dnv.com

Page 1 of 2

WISKA Hoppmann GmbH

Kisdorfer Weg 28
24568 Kaltenkirchen
Germany

Tel +49 (0) 4191 508-0
Fax +49 (0) 4191 508-129

contact@wiska.de
www.wiska.com